

REVISIONS			
ZONE	REV	DESCRIPTION	DATE AUTH

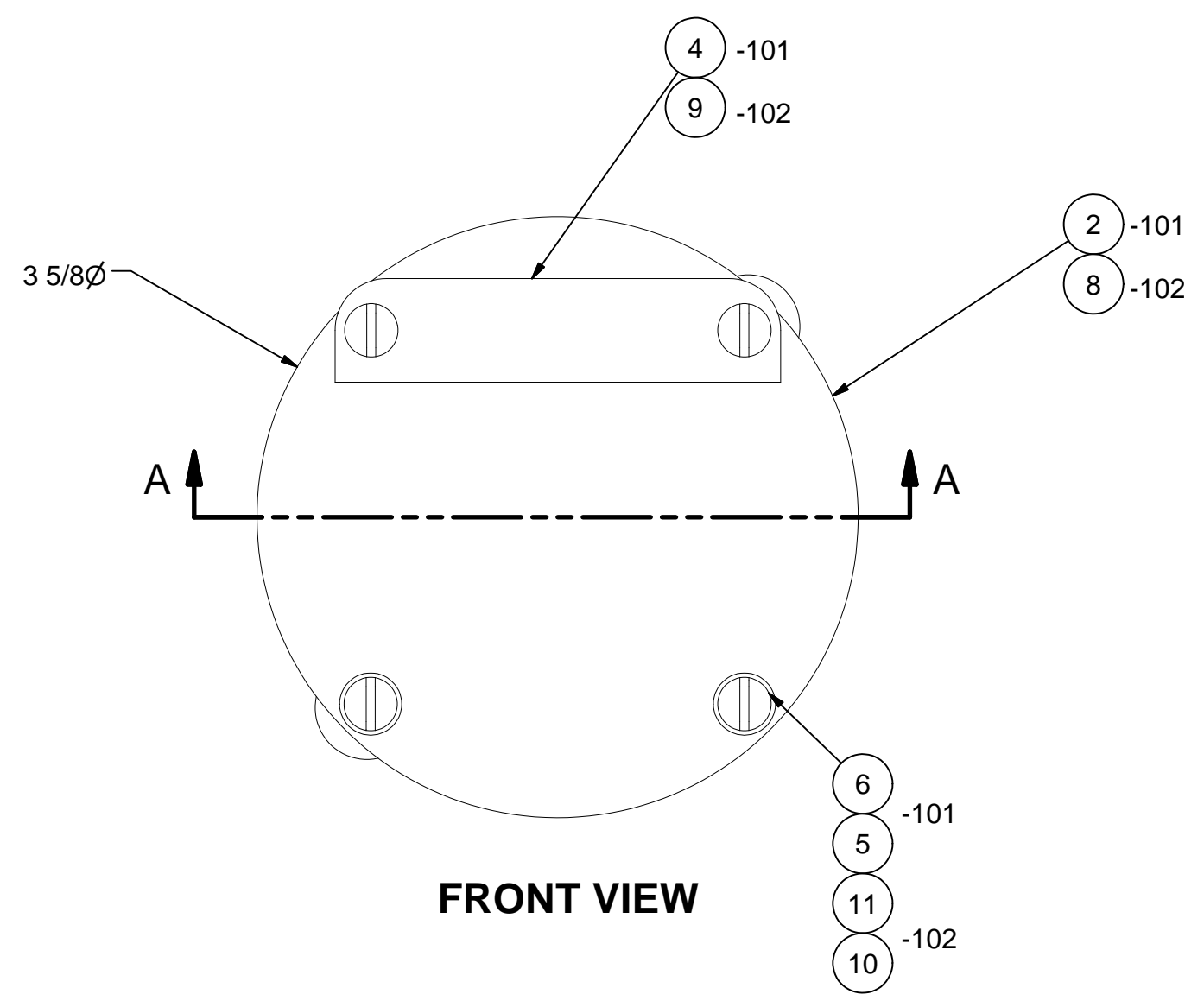

FRONT VIEW

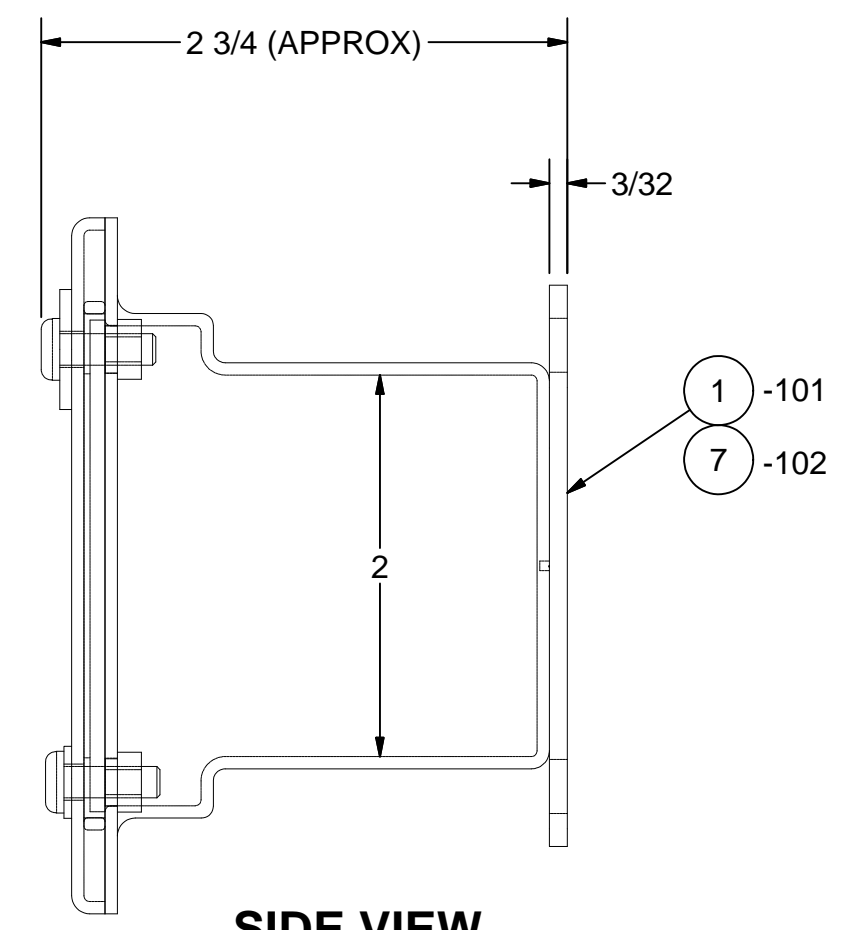

SIDE VIEW

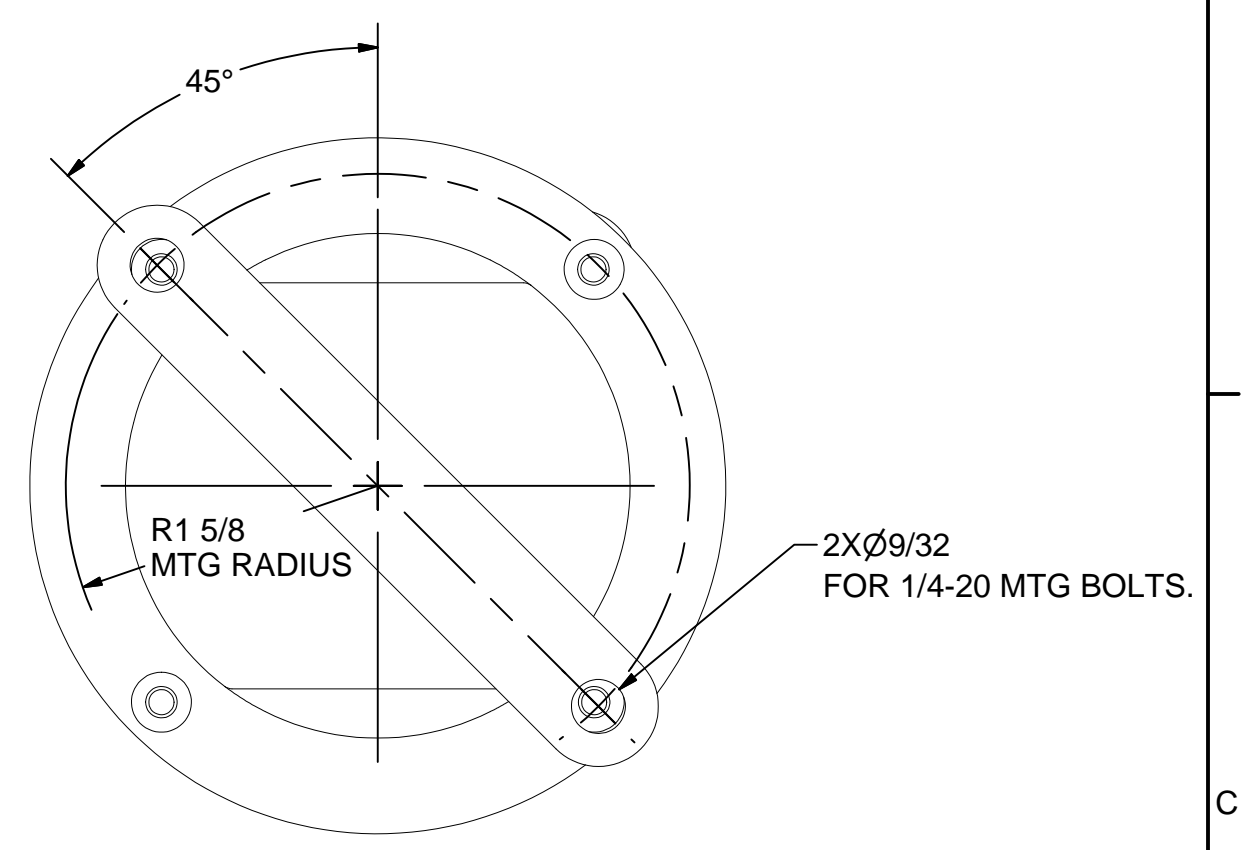

BACK VIEW

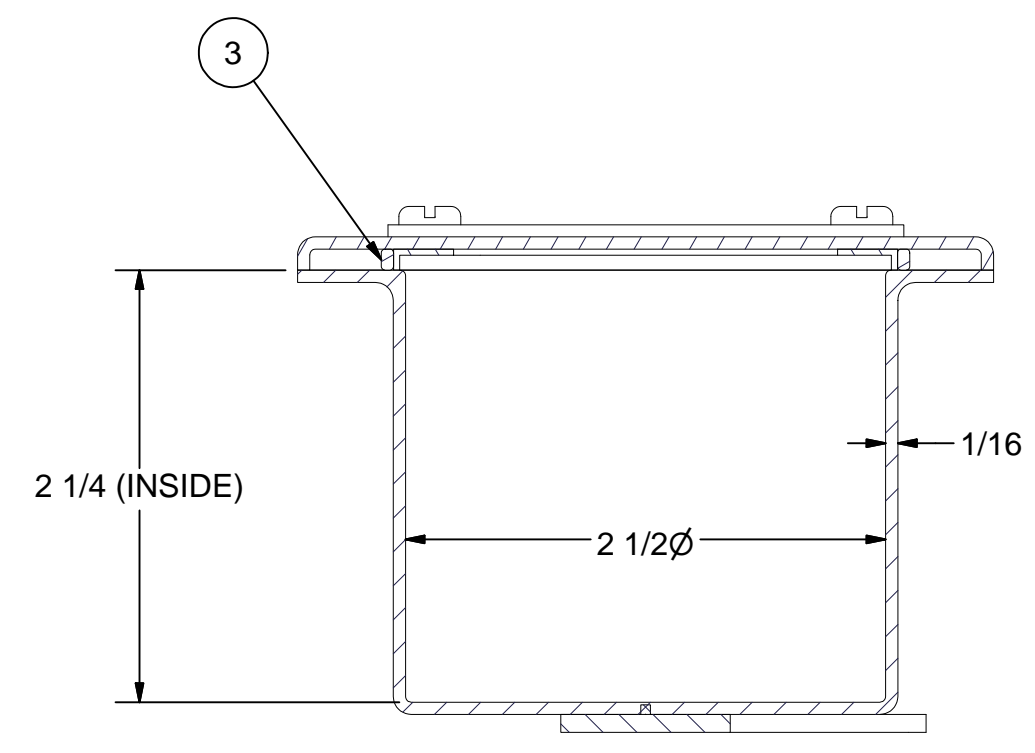

SECTION A-A

(2) FLAT SIDES, 1-1/2" X 1-1/2".
CAN HOLD UP TO SIZE #3 NYLON STUFFING TUBE.

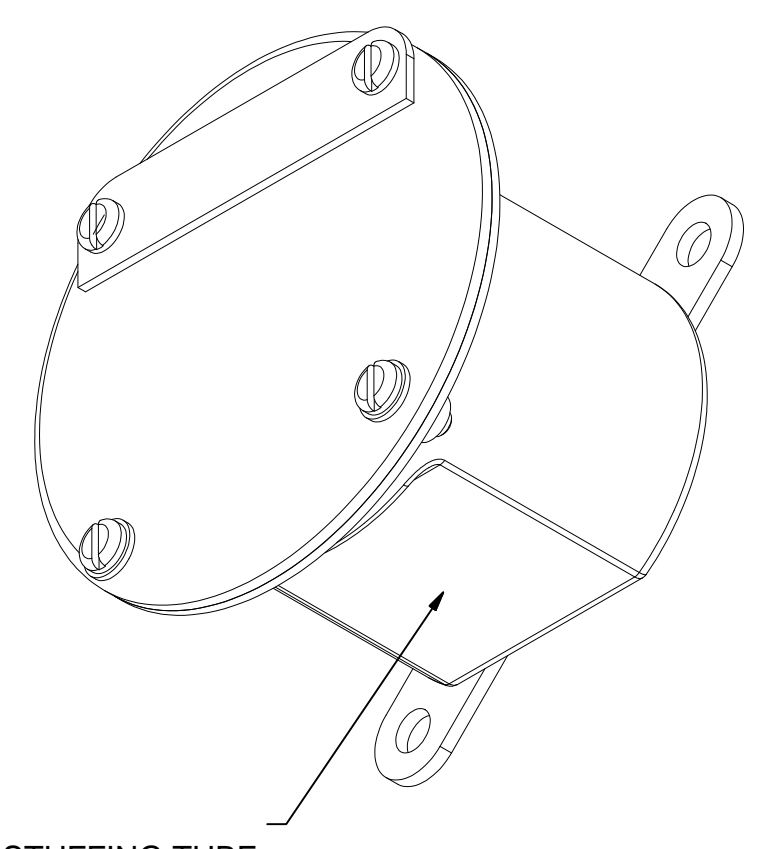

ASSEMBLY		Parts List		
-102	-101	ITEM	PART NUMBER	DESCRIPTION
—	1	1	200201	BOX WELDMENT, BRASS, 2-1/2" RND
—	1	2	200835	COVER WELDMENT, BRASS, 2-1/2" RND
1	1	3	MS28775-231	"O" RING COVER GASKET, RUBBER
—	1	4	100312	INFO PLATE, BRASS, BLANK
—	2	5	X-FLW-BRS-8	WASHER, FLAT, BRASS, #8
—	4	6	X-RHM-BRS-832-0500	SCREW, RHM, BRASS, 8-32 X 1/2"
1	—	7	20201-102	BOX WELDMENT, ALUM, 2-1/2" RND
1	—	8	200928	COVER WELDMENT, ALUM, 2-1/2" RND
1	—	9	100312-1	INFO PLATE, ALUM, BLANK
2	—	10	X-FLW-CRES-8	WASHER, FLAT, CRES, #8
4	—	11	X-RHM-SS-832-0500	SCREW, RHM, CRES, 8-32 X 1/2"

- NOTES:**
- MATERIAL: BRASS, PER ASTM B-36, ALUMINUM PER ASTM-B209.
 - SHEET METAL GAGE: PRIOR TO DRAWING SHALL BE 1/16".
 - EFFECTIVENESS OF ENCLOSURE TIGHTNESS: SUBMERSIBLE 15 FEET PER MIL-STD-108.
 - ENCLOSURE SHALL WITHSTAND SHOCK TEST PER MIL-S-901 FOR GRADE A, CLASS I, TYPE A EQUIPMENT AND VIBRATION TEST PER MIL-STD-167-1, TYPE 1.
 - THIS DRAWING DEVELOPED FROM BUREAU OF SHIPS 9-S-73754.
 - WEIGHT: BRASS ENCLOSURE .88 LBS, ALUMINUM ENCLOSURE .44 LBS.
 - ALUMINUM ENCLOSURE FINISHED WITH GREY ENAMEL ALL SURFACES.

THIS DRAWING/DOCUMENT CONTAINS INFORMATION WHICH IS PROPRIETARY TO AND PROPERTY OF COMSACO, INC. IT IS DISTRIBUTED WITH THE UNDERSTANDING THAT IT WILL BE RETAINED IN CONFIDENCE AND WILL NEITHER BE DUPLICATED NOR COPIED IN WHOLE OR IN PART NOR USED FOR ANY PURPOSE OTHER THAN THAT FOR WHICH DISCLOSED WITHOUT EXPRESS WRITTEN PERMISSION FROM COMSACO, INC.

UNLESS OTHERWISE SPECIFIED DIMENSIONS ARE IN INCHES TOLERANCES ARE:
FRACTIONS DECIMALS ANGLES
+/- 1/64 .XX .XXX .005

DRAWN
CHRIS WINDLEY
7/30/2008

CHECKED
W WESTHOFF
7/31/2008

QA

MFG

APPROVED

COMSACO, INC.
NORFOLK, VA. 23502

TITLE
ENCLOSURE FOR ELECTRICAL FITTINGS AND FIXTURES, 2-1/2" ROUND, SBM-15

SIZE CODE IDENT NO. DWG NO. REV
C 57626 404900 -

SCALE SHEET 1 OF 1

NEXT ASSY	USED ON