

ZONE REV		REVISIONS		DATE	AUTH
		DESCRIPTION			

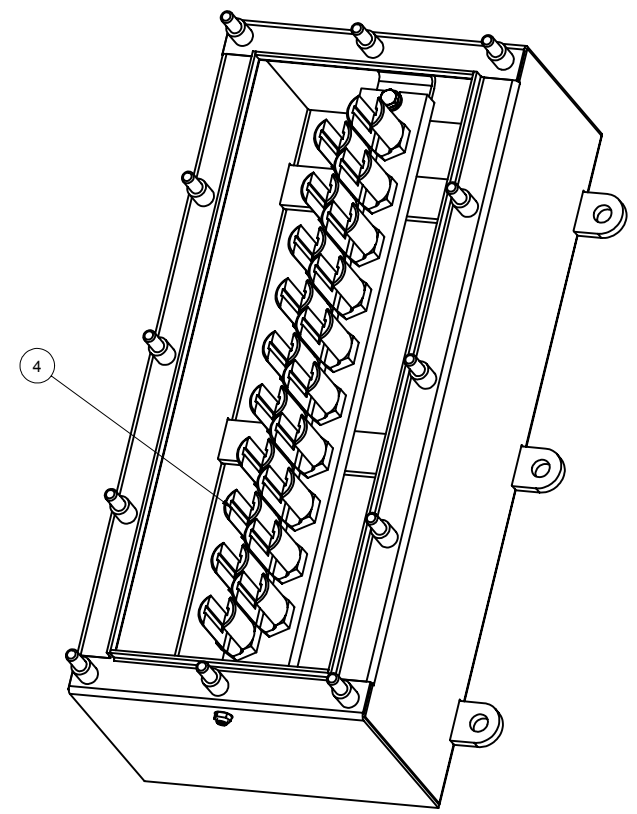
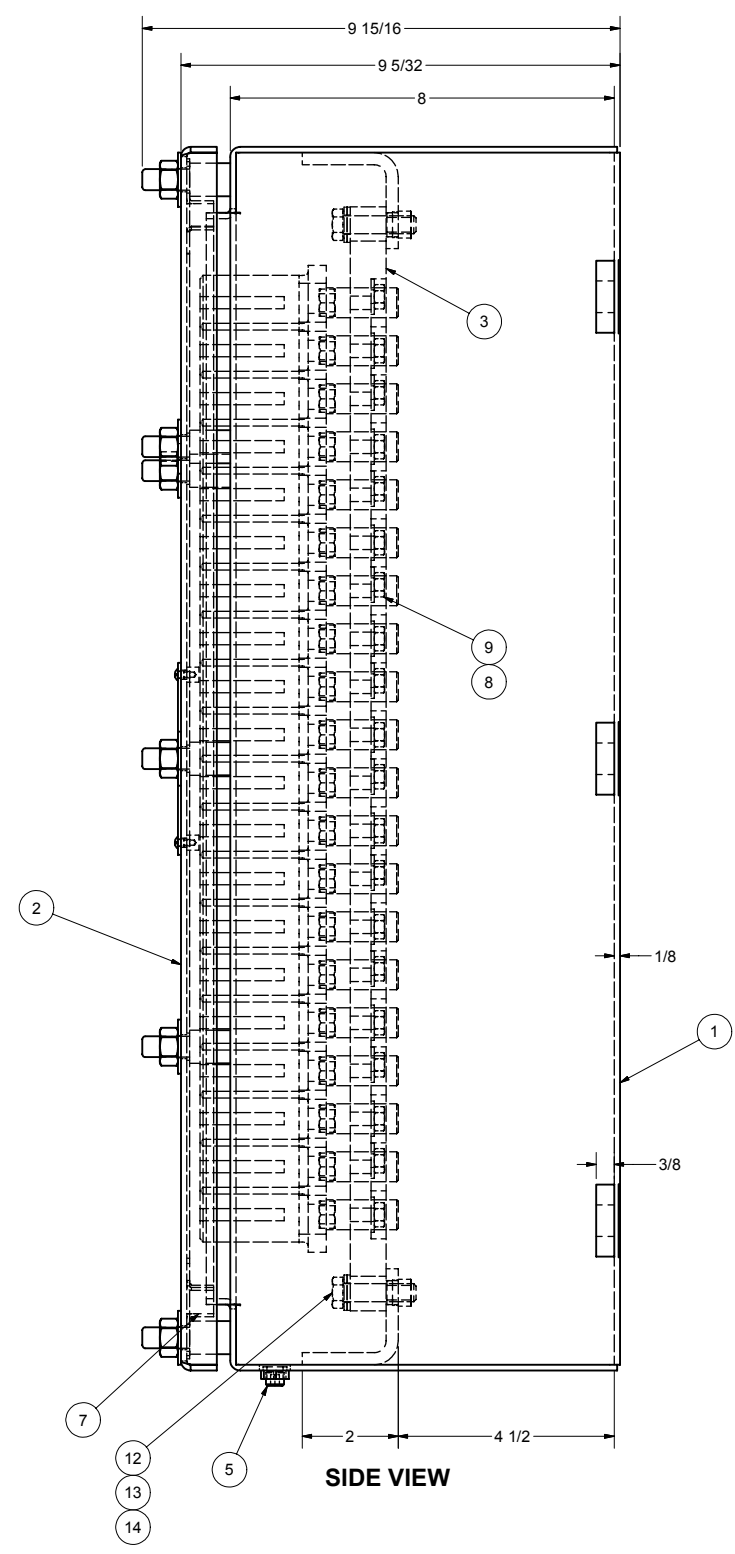
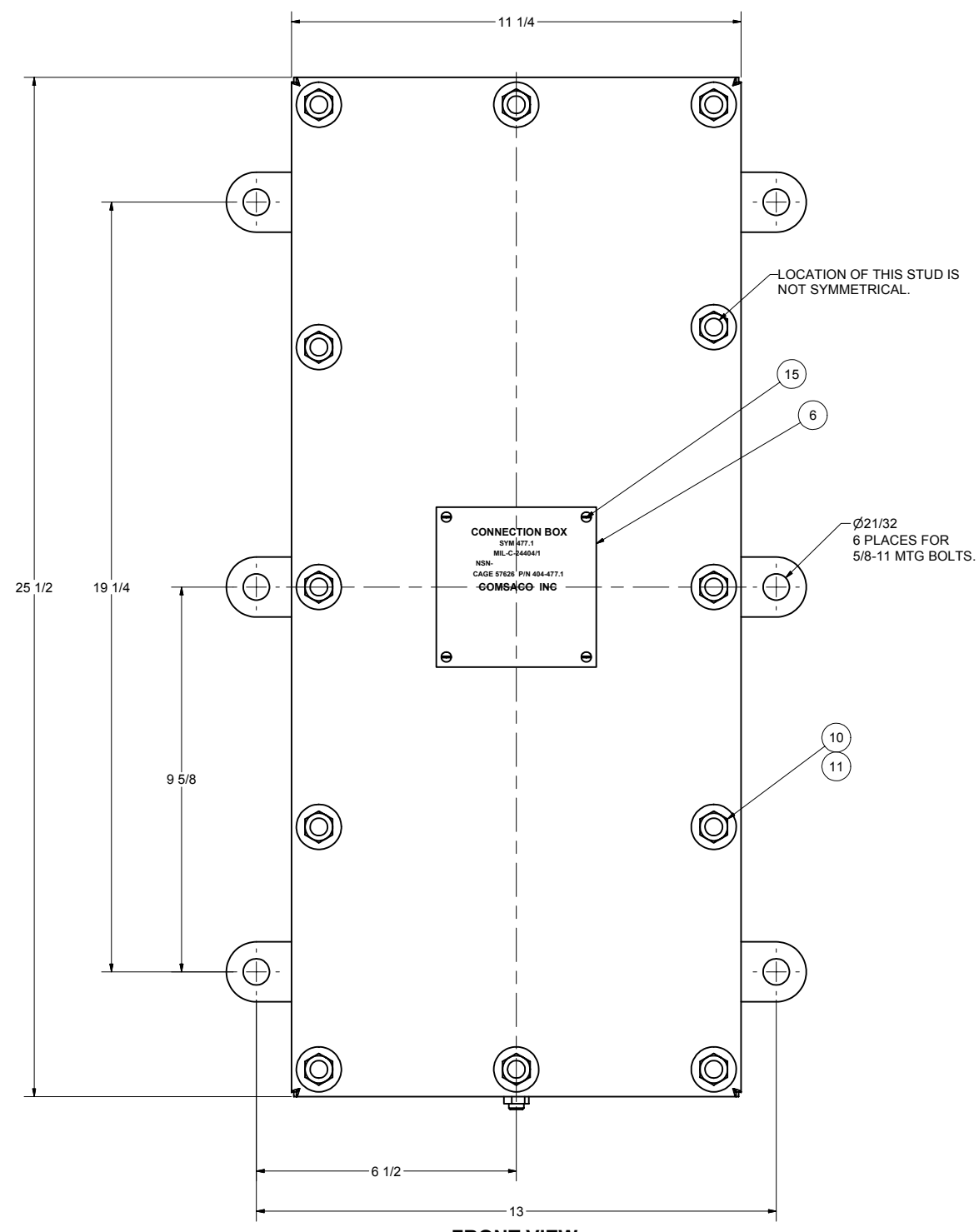

SYM 477.1 W/O COVER

- NOTES:
- TOTAL WEIGHT IS 65 LBS (EST).
 - ELECTRICAL RATING IS 250V, FOR 20 TERMINALS FOR A MAXIMUM OF 40 CABLES 6,500 TO 13,090 CM. (12-10 AWG)
 - UNLESS OTHERWISE SPECIFIED CABLE ENTRANCE DEVICES WILL BE PROVIDED BY THE INSTALLING ACTIVITY.
 - TESTS:
 - VIBRATION PER MIL-STD-167 TYPE I, EXPLORATORY, VARIABLE AND ENDURANCE UP TO 25HZ.
 - SHOCK PER MIL-S-901D: MEDIUM WEIGHT, HIGH IMPACT, GRADE A.
 - EFFECTIVENESS OF ENCLOSURE PER MIL-STD-108. (SBM-15FT).
 - FINISH AS FOLLOWS:
 - PRIME WITH ZINC-MOLYBDATE PER TT-P-645.
 - PAINT EXTERIOR WITH LIGHT GRAY ENAMEL.
 - PAINT INTERIOR WITH WHITE ENAMEL.
 - THIS DRAWING DEVELOPED FROM MIL-C-24404/1.

Parts List				
ITEM	QTY	PART NUMBER	DESCRIPTION	
1	1	200220	BOX WELDMENT, 11GA STEEL	
2	1	200221	COVER WELDMENT, 11GA STEEL	
3	1	100256-1	TERMINAL STRIP, 3/4" THICK GME	
4	20	DGM-1L	TERMINAL, BRONZE OR BRASS	
5	1	73142-30	PLUG, PIPE, BRASS, 1/8" IPS, 3/16" HEX	
6	1	100244-6	ID PLATE, BRASS	
7	6	Z-R-SQR-0500-R900	RUBBER STRIP, 1/2" X 1/2", PER MIL-R-900	
8	20	X-ELW-CRES-0250	WASHER, EXT TOOTH, 1/4"	
9	20	X-NUT-CRES-0420	HEX NUT, CRES, 1/4-20	
10	12	X-NUT-CRES-716-14	HEX NUT, CRES, 7/16-14	
11	12	X-FLW-CRES-716	WASHER, FLAT, CRES, 7/16"	
12	2	X-BLT-SS-816-1.50	BOLT, HEX HEAD, CRES, 3/8-16 X 1-1/2"	
13	2	X-FLW-CRES-375	WASHER, FLAT, CRES, 3/8"	
14	2	X-ELW-CRES-375	WASHER, EXT TOOTH, CRES, 3/8"	
15	4	X-RHM-BRS-632-250	SCREW, RHM, BRASS, 6-32 X 1/4"	

DRAWN	CHRIS WINDLEY	3/29/2005
CHECKED	W WESTHOFF	4/14/2005
QA		
MFG		
APPROVED		

COMSACO, INC.
NORFOLK, VA. 23502

DEGAUSSING CONNECTION BOX, SYM 477.1

SIZE: D 57626 CODE IDENT NO: 404-477.1 DWG NO: REV: -

SCALE: SHEET 1 OF 1

UNLESS OTHERWISE SPECIFIED
DIMENSIONS ARE IN INCHES
TOLERANCES ARE:
FRACTIONS DECIMALS ANGLES
+/- 1/64 .XX .XXX .005

NEXT ASSY	USED ON
-----------	---------