

M24558/10 SYM 438  
NSN 5940-00-351-2228  
CAGE 57626 COMSACO

ZONE REV		REVISIONS		DATE	AUTH
ALL	A	REVISED: DWG INTO CAD FORMAT		3/8/12	WW

ITEM 9

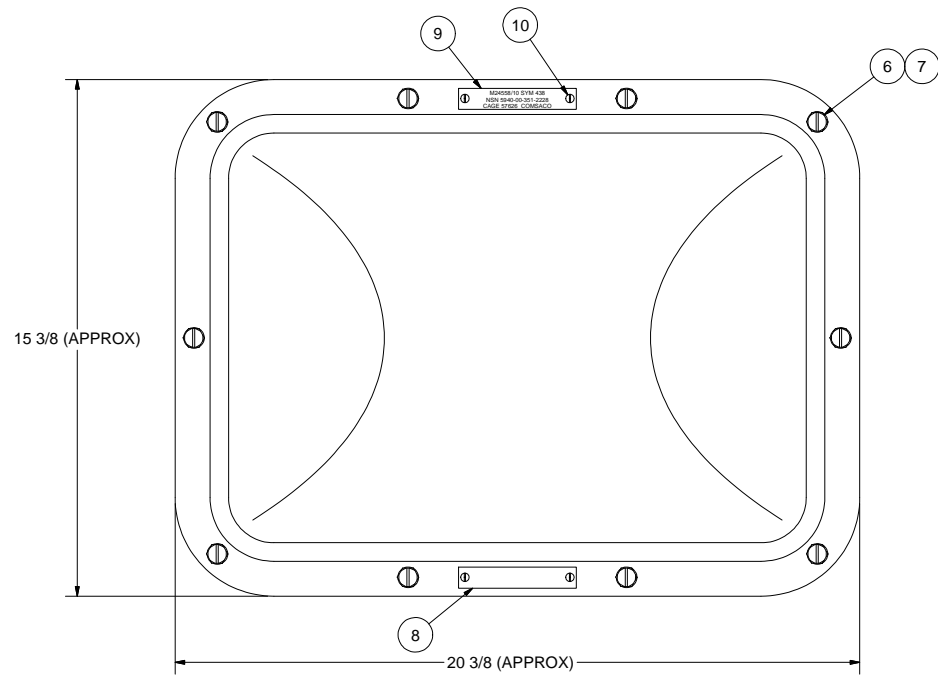

FRONT VIEW

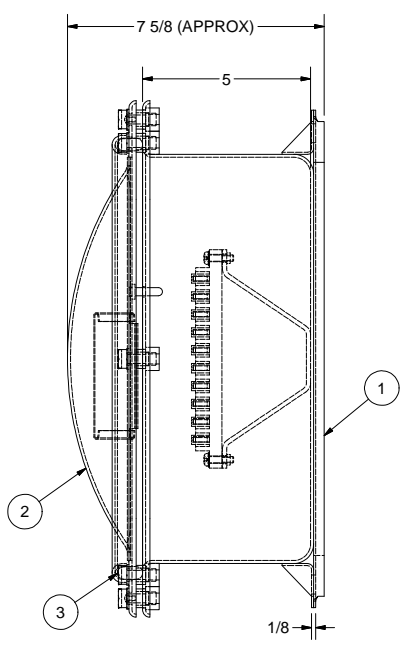

SIDE VIEW

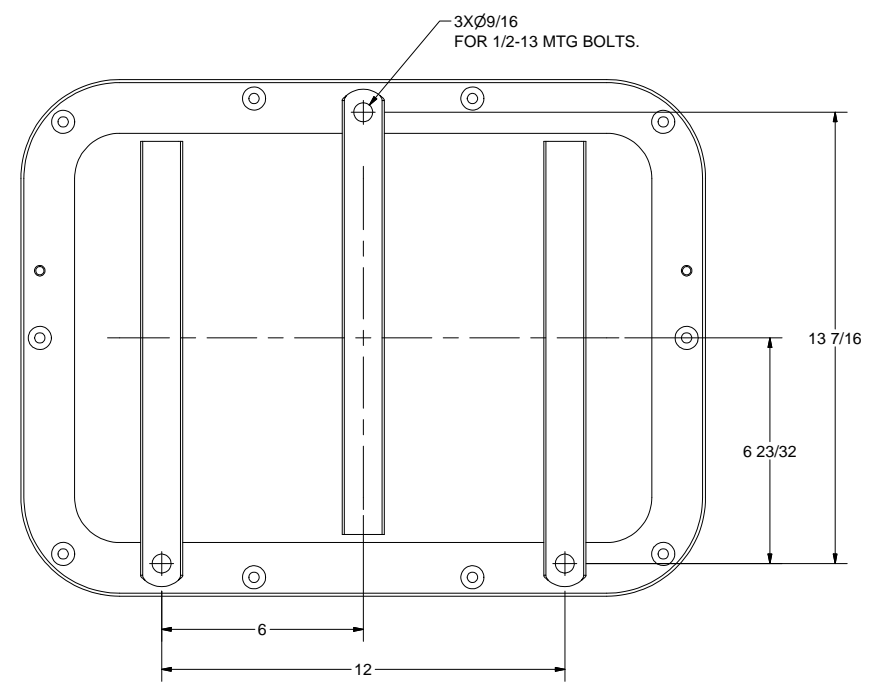

BACK VIEW

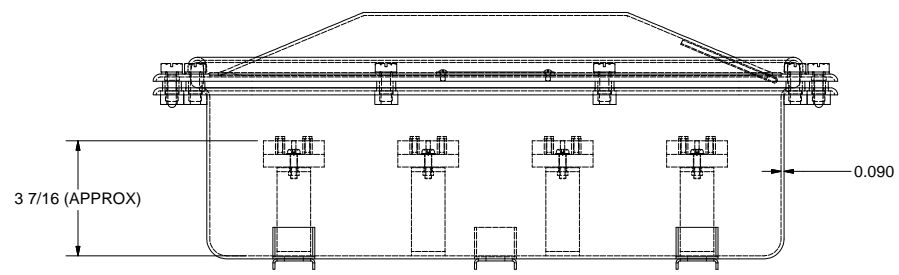

BOTTOM VIEW

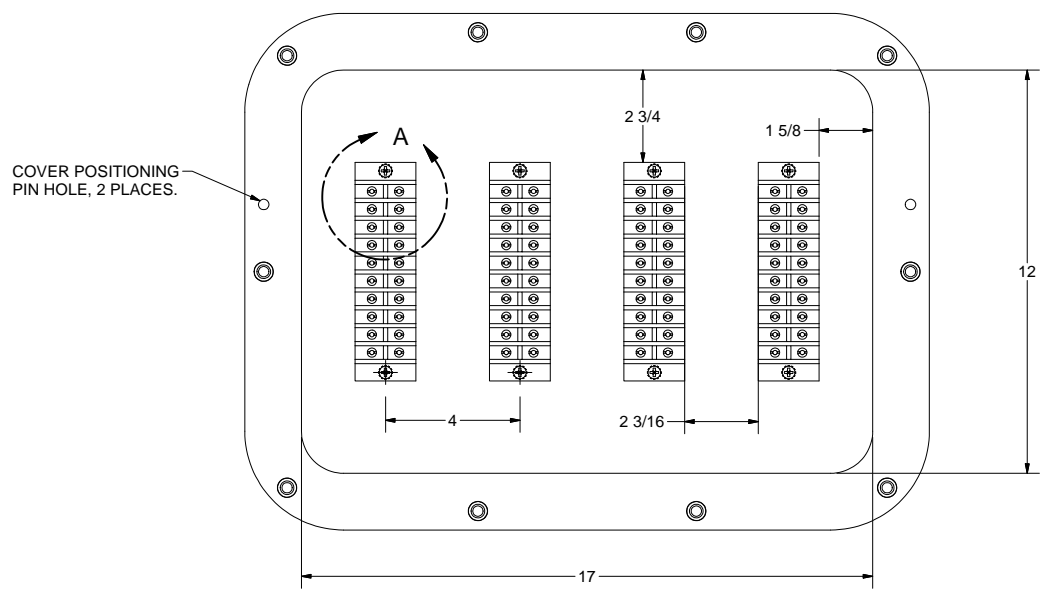

FRONT VIEW LESS COVER

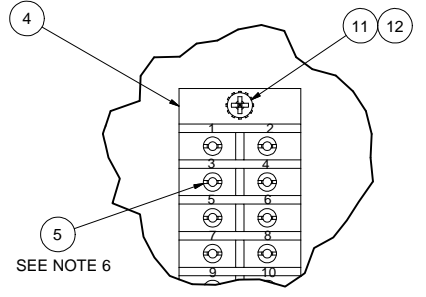

DETAIL A

- NOTES:
- THIS DRAWING DEVELOPED FROM MIL-DTL-24558/10B.
  - RATINGS AND SPECIFICATIONS:
    - 600 VOLTS, 40 AMPS MAXIMUM PER STUD OF TERMINAL BOARD.
    - 80 TERMINALS, 320 WIRES MAX.
    - DEGREE OF ENCLOSURE: SUBMERSIBLE TO 15 FEET (SBM-15) PER MIL-STD-108.
    - MAGNETIC PERMEABILITY: LESS THAN 2.0 FERROUS MATERIALS: NONE.
    - WEIGHT: 33 LBS MAX.
  - UNLESS OTHERWISE SPECIFIED, CABLE ENTRANCE DEVICES WILL BE PROVIDED AND INSTALLED BY THE INSTALLING ACTIVITY.
  - TERMINAL BOARDS ARE MOLDED BARRIER STUD TYPE, CLASS 4TB PER A-A-59125/10, MAXIMUM LUGS PER STUD IS 4. BU-SHIPS TYPE L80. STUDS ARE 8-32.
  - SHOCK AND VIBRATION APPROVAL BY EXTENSION HAS BEEN GRANTED FOR THIS EQUIPMENT BASED ON SIMILARITY TO M24142/6-014 ENCLOSURE PER SUPERVISOR OF SHIPBUILDING, CONVERSION AND REPAIR, USN, NEWPORT NEWS, LTR 9072 SER SSN688C1-273B/1479, DATED 11 AUG 1989. M24142/6-014 HAS PASSED FIRST ARTICLE TESTING PER COMSACO REPORT FA-1008 AND AERO-NAV LABORATORIES TEST REPORT 8-0328, DATED 23 JUNE 1988. TESTS INCLUDED LIGHTWEIGHT SHOCK GRADE A, CLASS 1, TYPE A PER MIL-S-901 AND TYPE 1 VIBRATION PER MIL-STD-167-1.
  - BARREL NUTS FOR TERMINAL BOARDS TO BE PACKAGED SECURELY AND SHIPPED LOOSE INSIDE ENCLOSURE.
  - FINISH: INTERIOR ONLY WITH WHITE ENAMEL.
  - ALUMINUM ASSEMBLY PROVIDED PER COMSACO PART NUMBER SYM 438 MA.

ITEM	QTY	PART NUMBER	DESCRIPTION
1	1	200135	BOX WELDMENT, BRASS, 12 X 17
2	1	200174-104	COVER WELDMENT, BRASS, 12 X 17
3	1	100146-9	GASKET, RUBBER, PER MIL-R-6822, CL I
4	4	4TB20	TERMINAL BOARD, 20T, A-A-59125/10
5	4	101250-4-20	BARREL NUT KIT, BRASS, (20 NUTS), 8-32
6	10	74031-5	BOLT, COVER, BRASS, 3/8-16 X 1-1/8"
7	10	AN960B616	WASHER, FLAT, BRASS, 3/8"
8	1	100260-1	INFO PLATE, BRASS
9	1	100260-438	NAMEPLATE, BRASS, ENGRAVED
10	4	X-RHM-BRS-632-250	RHMS, BRASS, 6-32 X 1/4"
11	8	X-RHM-BRS-024-750	RHMS, BRASS, 10-24 X 3/4"
12	8	X-ELW-PHB-10	WASHER, EXT TOOTH, PHOS BRONZE, #10

REDRAWN  
CHRIS WINDLEY 3/8/2012  
ORIGINAL ISSUE  
W WESTHOFF 6/9/1987  
QA  
MFG  
APPROVED

**COMSACO, INC.**  
NORFOLK, VA. 23502

**TERMINAL BOX ASSY, BRASS,  
12 X 17, SYM 438**

SIZE CODE IDENT NO DWG NO  
D 57626 404-438

SCALE SHEET 1 OF 1

UNLESS OTHERWISE SPECIFIED  
DIMENSIONS ARE IN INCHES  
TOLERANCES ARE:  
FRACTIONS DECIMALS ANGLES  
+/- 1/64 .XX .XXX .005

NEXT ASSY	USED ON